

# RBC Track Runners

## Heavy-Duty Stud-Type Track Rollers



*Smoother. Faster. Longer.*

*Because That's How We Roll.* \_\_\_\_\_

# RBC Track Runner – Plain Track Rollers

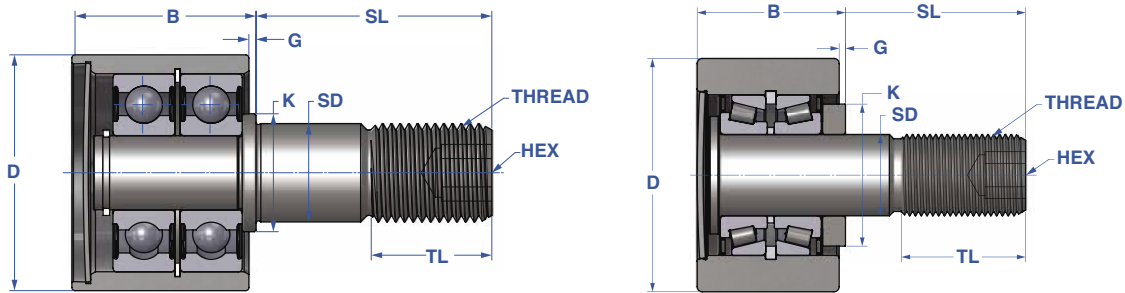

Ball Bearing (BB) Style

Tapered Roller Bearing (TRB) Style

RBC PART NUMBER	BEARING Ball (BB) or Tapered Roller (TRB)	ROLLER		Shank Dia. +.000 -.001	STUD			SHOULDER		CAPACITIES			
		Outside Dia. +.000 -.001	Width		Shank Length	Min. Eff. Thread Length	Thread Class	Dia.	Length	Dynamic Radial Load lbs	Static Thrust Load lbs	Static Radial Load lbs	
		D	B		SD	SL	TL	2A	HEX	K	G		
PTR 1	BB	1.000	0.781	0.437	1.000	0.500	7/16-20	3/16	0.500	0.031	630	140	230
PTR 1 1/8	BB	1.125	0.781	0.437	1.000	0.500	7/16-20	3/16	0.500	0.031	630	140	230
PTR 1 1/4	BB	1.250	0.844	0.500	1.250	0.625	1/2-20	3/16	0.625	0.031	1,350	370	600
PTR 1 3/8	BB	1.375	0.844	0.500	1.250	0.625	1/2-20	3/16	0.625	0.031	1,350	370	600
PTR 1 1/2	BB	1.500	1.187	0.625	1.500	0.750	5/8-18	5/16	0.750	0.062	2,760	680	1,100
PTR 1 3/4	BB	1.750	1.187	0.750	1.750	0.875	3/4-16	5/16	1.000	0.062	2,760	680	1,100
PTR 2	BB	2.000	1.687	0.875	2.000	1.125	7/8-14	5/16	1.000	0.062	3,830	1,000	1,620
PTR 2 1/4	BB	2.250	1.687	0.875	2.000	1.125	7/8-14	5/16	1.000	0.062	3,830	1,000	1,620
PTR 2 1/2	BB	2.500	1.687	1.000	2.250	1.500	1-14	1/2	1.250	0.062	5,190	1,400	2,270
PTR 2 3/4	BB	2.750	1.687	1.000	2.250	1.500	1-14	1/2	1.250	0.062	5,190	1,400	2,270
PTR 3	TRB	3.000	2.000	1.250	2.500	1.750	1 1/4-12	1/2	1.750	0.062	14,270	12,000	20,000
PTR 3 1/4	TRB	3.250	2.000	1.250	2.500	1.750	1 1/4-12	1/2	1.750	0.062	14,270	12,000	20,000
PTR 3 1/2	TRB	3.500	2.000	1.250	2.750	1.750	1 1/4-12	1/2	1.750	0.062	14,270	12,000	20,000
PTR 4	TRB	4.000	2.000	1.250	2.750	1.750	1 1/4-12	1/2	1.750	0.062	14,270	12,000	20,000
PTR 4 1/2	TRB	4.500	2.000	1.250	2.750	1.750	1 1/4-12	1/2	1.750	0.062	14,270	12,000	20,000
PTR 5	TRB	5.000	3.000	2.000	4.500	2.500	2-12	5/8	3.250	0.062	33,290	32,500	51,900
PTR 6	TRB	6.000	3.000	2.500	5.500	3.250	2 1/2-12	5/8	3.250	0.062	35,840	33,100	56,400
PTR 7	TRB	7.000	3.000	2.500	5.500	3.250	2 1/2-12	5/8	3.250	0.062	35,840	33,100	56,400
PTR 8	TRB	8.000	3.000	2.500	5.500	3.250	2 1/2-12	5/8	3.250	0.062	35,840	33,100	56,400
PTR 10	TRB	10.000	5.000	2.500	5.500	3.250	2 1/2-12	5/8	3.250	0.062	35,840	33,100	56,400

To specify eccentric stud: add "E" to the part number (example [PTRE 1 1/2](#))

To specify a nut and lock washer: add the "NW" suffix, (example [PTR 2 1/2 NW](#))

Style - Straight OD	RBC Part Number	Osborn Part Number	McGill Part Number
	<a href="#">PTR 1 1/2</a>	<a href="#">PLR 1-1/2</a>	<a href="#">PCF 1-1/2</a>
	<a href="#">PTR 1 3/4</a>	<a href="#">PLR 1-3/4</a>	<a href="#">PCF 1-3/4</a>
	<a href="#">PTR 2</a>	<a href="#">PLR 2</a>	<a href="#">PCF 2</a>
	<a href="#">PTR 2 1/4</a>	<a href="#">PLR 2-1/4</a>	<a href="#">PCF 2-1/4</a>
	<a href="#">PTR 2 1/2</a>	<a href="#">PLR 2-1/2</a>	<a href="#">PCF 2-1/2</a>
	<a href="#">PTR 3</a>	<a href="#">PLR 3</a>	<a href="#">PCF 3</a>
	<a href="#">PTR 3 1/4</a>	<a href="#">PLR 3-1/4</a>	<a href="#">PCF 3-1/4</a>
	<a href="#">PTR 3 1/2</a>	<a href="#">PLR 3-1/2</a>	<a href="#">PCF 3-1/2</a>
	<a href="#">PTR 4</a>	<a href="#">PLR 4</a>	<a href="#">PCF 4</a>
	<a href="#">PTR 4 1/2</a>	<a href="#">PLR 4-1/2</a>	<a href="#">PCF 4-1/2</a>
	<a href="#">PTR 5</a>	<a href="#">PLR 5</a>	<a href="#">PCF 5</a>
	<a href="#">PTR 6</a>	<a href="#">PLR 6</a>	<a href="#">PCF 6</a>
	<a href="#">PTR 7</a>	<a href="#">PLR 7</a>	<a href="#">PCF 7</a>
	<a href="#">PTR 8</a>	<a href="#">PLR 8</a>	<a href="#">PCF 8</a>
	<a href="#">PTR 10</a>	<a href="#">PLR 10</a>	<a href="#">PCF 10</a>

# RBC Track Runner – Flanged Track Rollers

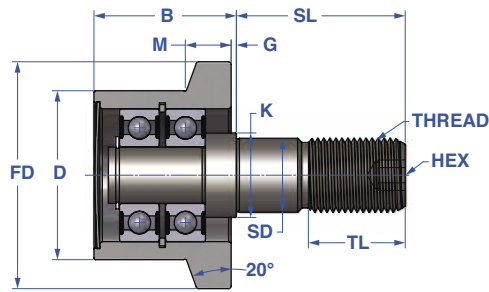

Ball Bearing (BB) Style

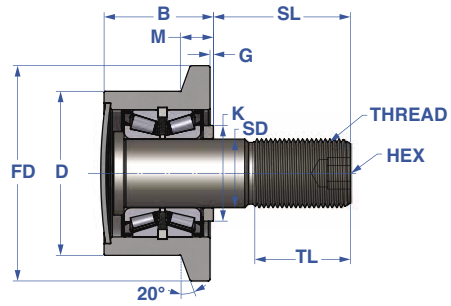

Tapered Roller Bearing (TRB) Style

RBC PART NUMBER	BEARING Ball (BB) or Tapered Roller (TRB)	ROLLER		STUD				SHOULDER		FLANGE		CAPACITIES			
		Outside Dia.	Width	Shank Dia., +.000 -.001	Shank Length,	Min. Eff. Thread Length,	Thread Class	Dia.	Length	Thickness	Dia.	Dynamic Radial Load lbs	Static Thrust Load lbs	Static Radial Load lbs	
		D	B	SD	SL	TL	2A	HEX	K	G	M	FD			
FTR 1	BB	1.000	0.781	0.437	1.000	0.500	7/16-20	3/16	0.500	0.031	0.219	1.375	630	140	230
FTR 1 1/8	BB	1.125	0.781	0.437	1.000	0.500	7/16-20	3/16	0.500	0.031	0.219	1.500	630	140	230
FTR 1 1/4	BB	1.250	0.844	0.500	1.250	0.625	1/2-20	3/16	0.625	0.031	0.219	1.563	1,350	370	600
FTR 1 3/8	BB	1.375	0.844	0.500	1.250	0.625	1/2-20	3/16	0.625	0.031	0.219	1.688	1,350	370	600
FTR 1 1/2	BB	1.500	1.188	0.625	1.500	0.750	5/8-18	5/16	0.750	0.062	0.343	2.188	2,760	680	1,100
FTR 1 3/4	BB	1.750	1.188	0.750	1.750	0.875	3/4-16	5/16	1.000	0.062	0.343	2.438	2,760	680	1,100
FTR 2	BB	2.000	1.688	0.875	2.000	1.125	7/8-14	5/16	1.000	0.062	0.593	2.688	3,830	1,000	1,620
FTR 2 1/4	BB	2.250	1.688	0.875	2.000	1.125	7/8-14	5/16	1.000	0.062	0.593	2.938	3,830	1,000	1,620
FTR 2 1/2	BB	2.500	1.688	1.000	2.250	1.500	1-14	1/2	1.250	0.062	0.593	3.188	5,190	1,400	2,270
FTR 2 3/4	BB	2.750	1.688	1.000	2.250	1.500	1-14	1/2	1.250	0.062	0.593	3.438	5,190	1,400	2,270
FTR 3	TRB	3.000	2.000	1.250	2.500	1.750	1 1/4-12	1/2	1.750	0.062	0.593	3.938	14,270	12,000	20,000
FTR 3 1/4	TRB	3.250	2.000	1.250	2.500	1.750	1 1/4-12	1/2	1.750	0.062	0.593	4.188	14,270	12,000	20,000
FTR 3 1/2	TRB	3.500	2.000	1.250	2.750	1.750	1 1/4-12	1/2	1.750	0.062	0.593	4.438	14,270	12,000	20,000
FTR 4	TRB	4.000	2.000	1.250	2.750	1.750	1 1/4-12	1/2	1.750	0.062	0.593	4.938	14,270	12,000	20,000
FTR 4 1/2	TRB	4.500	2.000	1.250	2.750	1.750	1 1/4-12	1/2	1.750	0.062	0.593	5.438	14,270	12,000	20,000
FTR 5	TRB	5.000	3.000	2.000	4.500	2.500	2-12	5/8	3.250	0.062	0.718	5.938	33,290	32,500	51,900
FTR 6	TRB	6.000	3.000	2.500	5.500	3.250	2 1/2-12	5/8	3.250	0.062	0.718	6.938	35,840	33,100	56,400
FTR 7	TRB	7.000	3.000	2.500	5.500	3.250	2 1/2-12	5/8	3.250	0.062	0.718	7.938	35,840	33,100	56,400
FTR 8	TRB	8.000	3.000	2.500	5.500	3.250	2 1/2-12	5/8	3.250	0.062	0.718	8.938	35,840	33,100	56,400

To specify eccentric stud: add "E" to the part number (example FTRE 1 1/2)

To specify a nut and lock washer: add the "NW" suffix, (example FTR 2 1/2 NW)

Style - Flanged OD	RBC Part Number	Osborn Part Number	McGill Part Number
	FTR 1 1/2	FLR 1-1/2	FCF 1-1/2
	FTR 1 3/4	FLR 1-3/4	FCF 1-3/4
	FTR 2	FLR 2	FCF 2
	FTR 2 1/4	FLR 2-1/4	FCF 2-1/4
	FTR 2 1/2	FLR 2-1/2	FCF 2-1/2
	FTR 3	FLR 3	FCF 3
	FTR 3 1/4	FLR 3-1/4	FCF 3-1/4
	FTR 3 1/2	FLR 3-1/2	FCF 3-1/2
	FTR 4	FLR 4	FCF 4
	FTR 4 1/2	FLR 4-1/2	FCF 4-1/2
	FTR 5	FLR 5	FCF 5
	FTR 6	FLR 6	FCF 6
	FTR 7	FLR 7	FCF 7
	FTR 8	FLR 8	FCF 8

# RBC Track Runner - V-Grooved, Stud style

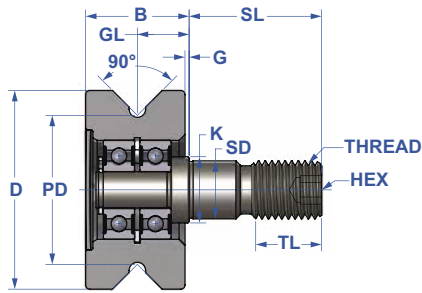

Ball Bearing (BB) Style

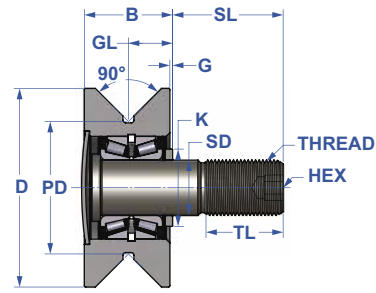

Tapered Roller Bearing (TRB) Style

RBC PART NUMBER	BEARING Ball (BB) or Tapered Roller (TRB)	ROLLER		STUD		SHOULDER		GROOVE		CAPACITIES					
		Outside Dia.	Width	Shank Dia.	Shank Length	Min. Eff. Thread Length	Thread Class	Length	Dia.	Point Dia.	Groove Location	Dynamic Radial Load lbs	Static Thrust Load lbs	Static Radial Load lbs	
		D	B	SD	SL	TL	2A	HEX	G	K	PD	GL			
VTR 1 1/2	BB	1.500	0.781	0.437	1.000	0.500	7/16-20	3/16	0.031	0.500	1.125	0.391	630	140	230
VTR 2	BB	2.000	0.844	0.500	1.250	0.625	1/2-20	3/16	0.031	0.625	1.375	0.422	1,350	370	600
VTR 2 1/2	BB	2.500	1.312	0.750	1.750	0.875	3/4-16	5/16	0.062	1.000	1.500	0.687	2,760	680	1,100
VTR 3 1/2	BB	3.500	1.687	0.875	2.000	1.125	7/8-14	5/16	0.062	1.000	2.250	0.875	5,190	1,400	2,270
VTR 4 1/2	TRB	4.500	2.000	1.250	2.500	1.750	1 1/4-12	1/2	0.062	1.750	3.000	1.000	14,270	12,000	20,000
VTR 5 1/2	TRB	5.500	2.000	1.250	2.750	1.750	1 1/4-12	1/2	0.062	1.750	4.000	1.000	14,270	12,000	20,000
VTR 6 1/2	TRB	6.500	3.000	2.000	4.500	2.500	2-12	5/8	0.062	3.250	5.000	1.500	35,840	33,100	56,400
VTR 7 1/2	TRB	7.500	3.000	2.500	5.500	3.250	2 1/2-12	5/8	0.062	3.250	6.000	1.500	35,840	33,100	56,400
VTR 8 1/2	TRB	8.500	3.000	2.500	5.500	3.250	2 1/2-12	5/8	0.062	3.250	7.000	1.500	35,840	33,100	56,400

To specify eccentric stud: add "E" to the part number (example [VTR E 1 1/2](#))

To specify a nut and lock washer: add the "NW" suffix, (example [VTR 2 1/2 NW](#))

Style - Yoke, Straight OD	RBC Part Number	Osborn Part Number	McGill Part Number
	VTR 1 1/2	VLR 1 - 1/2	
	VTR 2	VLR 2	
	VTR 2 1/2	VLR 2 - 1/2	VCF 2 1/2
	VTR 3 1/2	VLR 3 - 1/2	VCF 3 1/2
	VTR 4 1/2	VLR 4 - 1/2	VCF 4 1/2
	VTR 5 1/2	VLR 5 - 1/2	VCF 5 1/2
	VTR 6 1/2	VLR 6 - 1/2	VCF 6 1/2
	VTR 7 1/2	VLR 7 - 1/2	VCF 7 1/2
	VTR 8 1/2	VLR 8 - 1/2	VCF 8 1/2

# RBC Track Runner - Plain, Yoke style

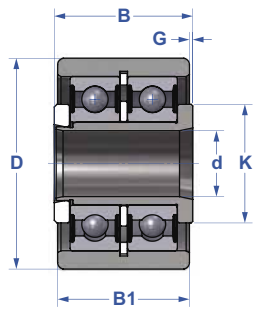

Ball Bearing (BB) Style

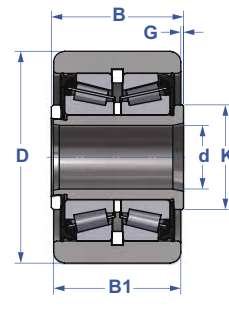

Tapered Roller Bearing (TRB) Style

RBC PART NUMBER	BEARING Ball (BB) or Tapered Roller (TRB)	ROLLER Outside Dia. +.000 -.001 D	Width B1	BORE		OVERALL WIDTH +.005 -.010 B	SHOULDER		CAPACITIES		
				Nom d	Tolerance		Length G	Dia. K	Dynamic Radial Load lbs	Static Thrust Load lbs	Static Radial Load lbs
PTRY 1 1/2	BB	1.500	0.875	0.437		0.937	0.031	0.875	1,850	480	780
PTRY 1 3/4	BB	1.750	1.000	0.500		1.063	0.031	1.000	1,850	480	780
PTRY 2	BB	2.000	1.250	0.625		1.313	0.031	1.125	3,400	1,120	1,810
PTRY 2 1/4	BB	2.250	1.250	0.625		1.313	0.031	1.125	3,400	1,120	1,810
PTRY 2 1/2	TRB	2.500	1.500	0.750		1.562	0.031	1.250	10,880	4,570	7,630
PTRY 3	TRB	3.000	1.750	1.000	+.0005 -.0000	1.812	0.031	1.750	14,270	12,000	20,000
PTRY 3 1/4	TRB	3.250	1.750	1.000		1.812	0.031	1.750	14,270	12,000	20,000
PTRY 3 1/2	TRB	3.500	2.000	1.125		2.062	0.031	2.000	17,590	13,100	27,200
PTRY 4	TRB	4.000	2.250	1.250		2.312	0.031	2.250	17,590	13,100	27,200
PTRY 5	TRB	5.000	2.750	1.750		2.875	0.062	3.250	33,290	32,500	51,900
PTRY 6	TRB	6.000	3.250	2.250		3.375	0.062	3.500	35,840	33,100	56,400
PTRY 7	TRB	7.000	3.750	2.750		3.875	0.062	4.250	42,430	48,400	79,800
PTRY 8	TRB	8.000	4.250	3.255	+.001 -.000	4.500	0.125	4.750	83,890	110,000	159,800
PTRY 9	TRB	9.000	4.750	3.755		5.000	0.125	5.500	134,230	147,000	250,000
PTRY 10	TRB	10.000	5.250	4.255		5.500	0.125	6.500	138,240	196,000	276,000

Style - Yoke, Straight OD	RBC Part Number	Osborn Part Number	McGill Part Number
	PTRY 1 1/2	PLRY 1 - 1/2	
	PTRY 1 3/4	PLRY 1 - 3/4	
	PTRY 2	PLRY 2	
	PTRY 2 1/4	PLRY 2 - 1/4	
	PTRY 2 1/2	PLRY 2 - 1/2	
	PTRY 3	PLRY 3	PCYR 3
	PTRY 3 1/4	PLRY 3 - 1/4	
	PTRY 3 1/2	PLRY 3 - 1/2	PCYR 3 1/2
	PTRY 4	PLRY 4	PCYR 4
	PTRY 5	PLRY 5	PCYR 5
PTRY 6	PLRY 6	PCYR 6	
PTRY 7	PLRY 7		
PTRY 8	PLRY 8		
PTRY 9	PLRY 9		
PTRY 10	PLRY 10		

# RBC Track Runner - Flanged, Yoke style

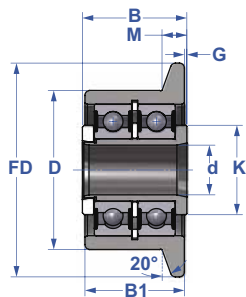

Ball Bearing (BB) Style

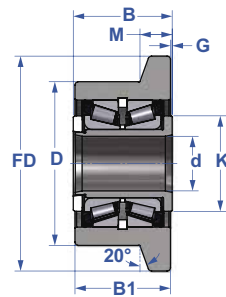

Tapered Roller Bearing (TRB) Style

RBC PART NUMBER	BEARING Ball (BB) or Tapered Roller (TRB)	ROLLER		BORE		OVERALL WIDTH  +0.005 -0.010	FLANGE		SHOULDER		CAPACITIES		
		Outside Dia.  D	Width  B1	Nom  d	Tolerance		Dia.  FD	Groove location  M	Length  G	Dia.  K	Dynamic Radial Load lbs	Static Thrust Load lbs	Static Radial Load lbs
FTRY 1 1/2	BB	1.500	0.875	0.437		0.937	2.188	0.218	0.031	0.875	1,850	480	780
FTRY 1 3/4	BB	1.750	1.000	0.500		1.063	2.438	0.250	0.031	1.000	1,850	480	780
FTRY 2	BB	2.000	1.250	0.625		1.313	2.688	0.312	0.031	1.125	3,400	1,120	1,810
FTRY 2 1/4	BB	2.250	1.250	0.625		1.313	2.938	0.312	0.031	1.125	3,400	1,120	1,810
FTRY 2 1/2	TRB	2.500	1.500	0.750		1.562	3.187	0.500	0.031	1.250	10,880	4,570	7,630
FTRY 3	TRB	3.000	1.750	1.000	+0.0005 -0.0000	1.812	3.937	0.590	0.031	1.750	14,270	12,000	20,000
FTRY 3 1/4	TRB	3.250	1.750	1.000		1.812	4.187	0.590	0.031	1.750	14,270	12,000	20,000
FTRY 3 1/2	TRB	3.500	2.000	1.125		2.062	4.437	0.590	0.031	2.000	17,590	13,100	27,200
FTRY 4	TRB	4.000	2.250	1.250		2.312	4.937	0.590	0.031	2.250	17,590	13,100	27,200
FTRY 5	TRB	5.000	2.750	1.750		2.875	5.937	0.720	0.062	3.500	33,290	32,500	51,900
FTRY 6	TRB	6.000	3.250	2.250		3.375	6.937	0.720	0.062	3.500	35,840	33,100	56,400
FTRY 7	TRB	7.000	3.750	2.750		3.875	7.937	0.720	0.062	4.250	42,430	48,400	79,800
FTRY 8	TRB	8.000	4.250	3.255	+0.001 -0.000	4.500	8.937	0.720	0.125	4.750	83,890	110,000	159,800
FTRY 9	TRB	9.000	4.750	3.755		5.000	9.937	0.720	0.125	5.500	134,230	147,000	250,000
FTRY 10	TRB	10.000	5.250	4.255		5.500	10.937	0.720	0.125	6.500	138,240	196,000	276,000

Style - Yoke, Flanged OD	RBC Part Number	Osborn Part Number	McGill Part Number
	FTRY 1 1/2	FLRY 1 - 1/2	
	FTRY 1 3/4	FLRY 1 - 3/4	
	FTRY 2	FLRY 2	
	FTRY 2 1/4	FLRY 2 - 1/4	
	FTRY 2 1/2	FLRY 2 - 1/2	
	FTRY 3	FLRY 3	FCYR 3
	FTRY 3 1/4	FLRY 3- 1/4	FCYR 3 1/4
	FTRY 3 1/2	FLRY 3 - 1/2	FCYR3 1/2
	FTRY 4	FLRY 4	FCYR 4
	FTRY 5	FLRY 5	FCYR 5
FTRY 6	FLRY 6	FCYR 6	
FTRY 7	FLRY 7		
FTRY 8	FLRY 8		
FTRY 9	FLRY 9		
FTRY 10	FLRY 10		

# RBC Track Runner – V-Grooved, Yoke Style

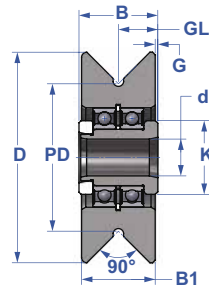

Ball Bearing (BB) Style

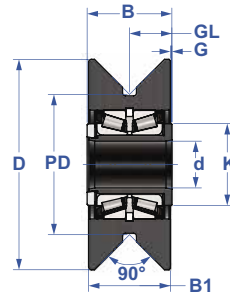

Tapered Roller Bearing (TRB) Style

RBC PART NUMBER	BEARING Ball (BB) or Tapered Roller (TRB)	ROLLER		BORE		OVERALL WIDTH  +0.005 -.010	GROOVE		SHOULDER		CAPACITIES		
		Outside Dia.	Width	Nom	Tolerance		Point Dia.	Groove location	Length	Dia.	Dynamic Radial Load lbs	Static Thrust Load lbs	Static Radial Load lbs
		D	B1	d		B	PD	GL	G	K			
VTRY 2 1/2	BB	2.500	0.875	0.437	+0.0005 -0.0000	0.937	1.750	0.468	0.031	0.875	1,850	480	780
VTRY 3	BB	3.000	1.250	0.625		1.312	2.062	0.656	0.031	1.125	3,400	1,120	1,810
VTRY 3 3/4	TRB	3.750	1.500	0.750		1.562	2.500	0.781	0.031	1.250	10,880	4,570	7,630
VTRY 4 1/2	TRB	4.500	1.750	1.000		1.812	3.000	0.906	0.031	1.750	14,270	12,000	20,000
VTRY 5	TRB	5.000	2.000	1.125		2.062	3.500	1.030	0.031	2.000	17,590	13,100	27,200
VTRY 5 1/2	TRB	5.500	2.250	1.250		2.312	4.000	1.156	0.031	2.250	17,590	13,100	27,200
VTRY 6 1/2	TRB	6.500	2.750	1.750		2.875	5.000	1.437	0.062	3.500	35,840	23,010	44,600
VTRY 7 1/2	TRB	7.500	3.250	2.250		3.375	6.000	1.687	0.062	3.500	35,840	26,930	52,600
VTRY 8 1/2	TRB	8.500	3.750	2.750		3.875	7.000	1.937	0.062	4.250	42,430	30,850	60,300
VTRY 9 1/2	TRB	9.500	4.250	3.255		+0.001 -0.000	4.500	8.000	2.250	0.125	4.750	69,540	34,770
VTRY 10 1/2	TRB	10.500	4.750	3.755	5.000		9.000	2.500	0.125	5.500	77,380	38,690	77,380
VTRY 11 1/2	TRB	11.500	5.250	4.255	5.500		10.000	2.750	0.125	6.500	85,220	42,610	85,220

\*Exceeds Static Capacity

Style - V-Grooved, Yoke	RBC Part Number	Osborn Part Number	McGill Part Number
	VTRY 2 1/2	VLRY 2 - 1/2	
	VTRY 3	VLRY 3	
	VTRY 3 3/4	VLRY 3 - 3/4	
	VTRY 4 1/2	VLRY 4 - 1/2	VCYR 4 1/2
	VTRY 5	VLRY 5	
	VTRY 5 1/2	VLRY 5 - 1/2	VCYR 5 1/2
	VTRY 6 1/2	VLRY 6 - 1/2	VCYR 6 1/2
	VTRY 7 1/2	VLRY 7 - 1/2	
	VTRY 8 1/2	VLRY 8 - 1/2	
	VTRY 9 1/2	VLRY 9 - 1/2	
	VTRY 10 1/2	VLRY 10 - 1/2	
VTRY 11 1/2	VLRY 11 - 1/2		



RBC Bearings® has been producing bearings in the USA since 1919. In addition to unique custom bearings, RBC Bearings® offers a full line of standard industrial and aerospace bearings, including:



### Tapered Roller Thrust Bearings

Case-hardened tapered roller thrust bearings for oilfield top drives and swivels. Available in full complement, maximum capacity versions.



### Thin Section Ball Bearings

Standard cross sections to one inch. Bore sizes to 40 inches. Stainless steel and other materials are available. Seals are available on all sizes and standard cross sections. Super duplex configurations.



### Cam Followers

Standard stud, heavy stud, yoke type, caged roller followers. Patented RBC Roller® cylindrical roller cam followers, HexLube® universal cam followers, airframe track rollers.



### Cylindrical Roller Bearings

Cylindrical roller bearings designed for mud pump pinion and eccentric positions. Fully interchangeable to industry standards.



### Needle Roller Bearings

Pitchline® caged heavy duty needle roller bearings ideal for cross head bearings applications. These double row bearings are available in single row and TandemRoller® versions.



### Commercial Rod Ends

Commercial and industrial, precision, Mil-Spec series, self-lubricating, and aircraft. Sold under the Heim®, Unibal®, and Spherco® names. Available in inch and metric sizes.

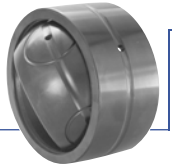

### Spherical Plain Bearings

Radial, angular contact, extended inner ring, high misalignment. QuadLube®, ImpactTuff®, SpreadLock® Seal, CrossLube®, DuraLube™, and self-lubricating bearings. Available in inch and metric sizes.



### Tapered Roller Bearings

Single, double, & multi row versions available for main bearing positions in mud pumps, gear boxes, etc. Bearings are constructed of case hardened steel washers and rollers with bore size of 11" or greater.

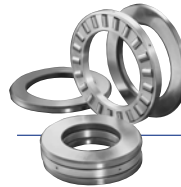

### TP Series Bearings

RBC Bearings® TP Series cylindrical roller thrust bearings ideal for crane hooks, oil well swivels, winch systems, and gear boxes. Fully interchangeable with industry standard offering.



### Keyless Locking Devices

Mechanical bushings used to connect power transmission components onto rotating shafts. Without the use of keyways, KLDs eliminate the problems associated with backlash including fretting, corroding, and wallowing.



### Lubron® Bearings

Lubron® self-lubricating bearings designed and custom manufactured in most any size, material and bearing configuration. Applications include hydro power and water control, nuclear power generation, infrastructure, architecture, offshore marine, industrial, machinery and heavy equipment.



### Shaft Collars

Used to position or locate a component on a shaft. Made from mild steel, type 303 or 316 stainless steel, aluminum, or acetal. Available in inch and metric sizes.



### Self-Lubricating Bearings

Radial, thrust, rod ends, spherical bearings, high temperature, high loads. Available in inch and metric sizes. Fiberglide® self-lubricating bearings.



### Specials

RBC Bearings® manufactures many specialty bearings for the aerospace, oil and energy, semiconductor equipment, packaging, transportation, and other industries.



### Ball Bearings

Precision ground, semiground, unground. High loads, long life, smooth operation. Nice® branded products are offered in caged and full complement configurations.



### Rigid Couplings

Shaft couplings serve as components to time, join, or align shafts at lower speeds and torque, especially when zero backlash is desired. Made from mild steel with a black oxide finish type 303 stainless steel, or aluminum. Available in inch and metric sizes.



### PIC Design

Complete line of precision gears, precision hardware, timing belts, pulleys, and linear motion systems. Industries served include industrial, aerospace, defense, medical, robotics and automation, material handling, and assembly. Custom design support for unique applications.