



CAM CLUTCH PRODUCTS

www.ustsubaki.com

Tsubaki Cam Clutch Solutions

Over the last 50 years, Tsubaki engineers have spent thousands of man hours designing and improving uni-directional/mechanical clutches in an effort to improve reliability and performance. Evolution of the uni-directional clutch started with simple prop and ratchet type designs, and has progressed to the roller ramp and non-contact sensing cam type commonly used today. Innovative designs and features incorporated into our cam clutch products assure efficient and dependable operation in the harshest environments.

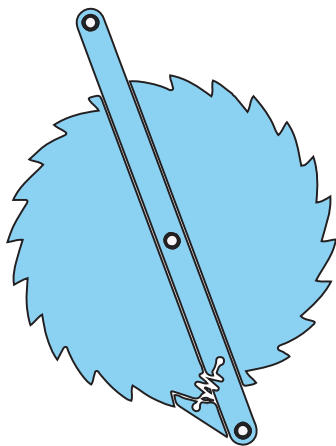
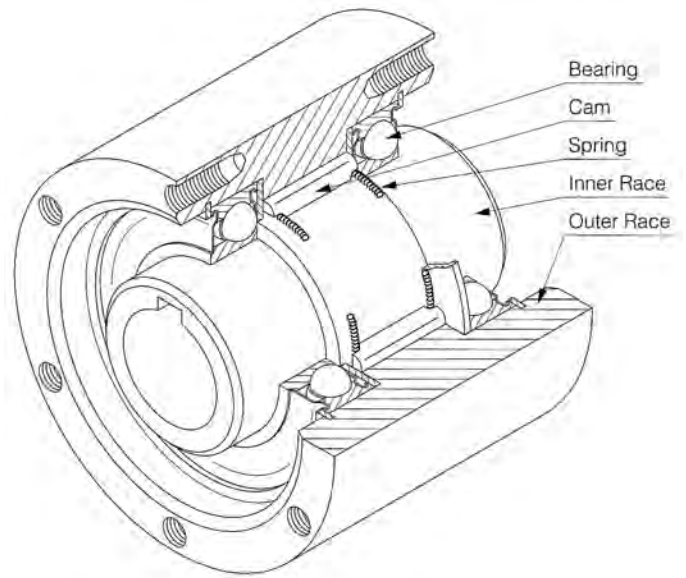

Ratchet Design

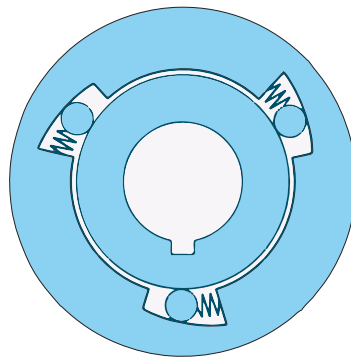

Roller Ramp Design

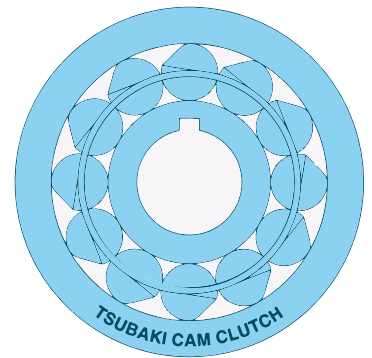

Tsubaki Sprag Design

Typical Applications

Air Cleaning Plants
Agricultural Machines
Bucket Elevators
Compressors
Conveyors
Cranes and Hoists
Dry Cleaning Machinery
Duplicator Equipment
Fish Net Machines

Heat-treatment Furnaces
Induced Draft Fans
Multi-state Conveyors
Packaging Machinery
Printing Machinery
Pumps
Punch Presses and Feeders
Power Plants

Refinery Equipment
Speed Reducers
Standby Power Units
Textile Looms
Two-speed Grinders
Two-speed Shiftovers
Washing Machines
Wire Winding Machines

Backstop Cam Clutch Products



BS

BS Series is designed for lower speed conveyor applications. The unique non-rollover cam design provides higher torque capacity, assuring full engagement.

Bore Range: 0.750" to 5.315"
(20 to 135 mm)

Torque Range: 217 to 11,580 lbs. ft.

Competitor Models:

Formsprag LLH
Falk NRTH
Ringspann FRH



BS-F

BS-F Series is designed for simple, drop-in installations to all major competitive backstop products. Uses unique seal design for maximum life, minimal maintenance.

Bore Range: 2.360" to 18.310"
(60 to 465 mm)

Torque Range: 4,980 to 722,000 lbs. ft.

Competitor Models:

Morse CB
Falk NRT
Marland MA
Formsprag LLH

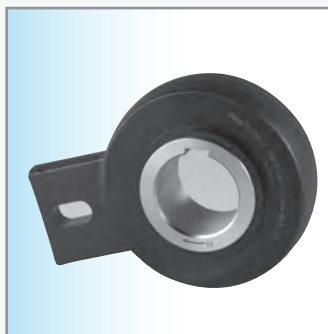

BSEU

BSEU Cam Clutches are a European variation popular on many bucket elevators in North and South America.

Bore Range: 0.787" to 3.543"
(20 to 90 mm)

Torque Range: 159 to 3,467 lbs. ft.

Competitor Models:

Formsprag RSBW
Morse CR/BW
Stieber RSBW

Indexing, Overrun



MZEU

MZEU Series is designed for overrunning applications. These units come pre-lubricated, and can be adapted with flanges and torque arms to suit a wide variety of applications.

Bore Range: 0.472" to 5.906"
(12 to 150 mm)

Torque Range: 44 to 24,930 lbs. ft.

Competitor Models:

Formsprag GFR/GFRN
Stieber GFR



BREU

BREU Series is designed for backstop applications where bearing support and modular construction is desirable.

Bore Range: 1.181" to 5.906"
(30 to 150 mm)

Torque Range: 447 to 25,009 lbs. ft.

Competitor Models:

Formsprag RIZ
Stieber RIZ

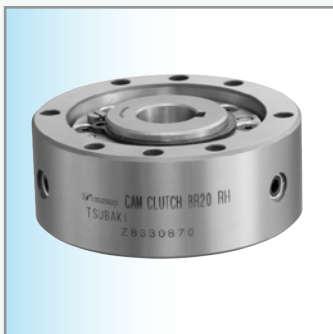

BR-HT

BR-HT Series is designed for backstop applications where high-speed overrunning is required. Lift off cam design assures minimal heat generation and longest life.

Bore Range: 0.787" to 5.118"
(20 to 320 mm)

Torque Range: 77 to 269,950 lbs. ft.

Competitor Models:

Formsprag RSCI
Ringspann FXM

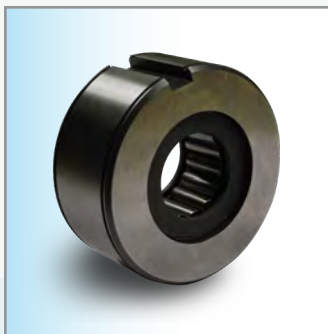

CA

CA line of backstops are an integral part of the reducer. The unique non-rollover cam design is key and prevents damage to the gears, shafts and drive train. This is a drop-in replacement for Dodge® reducers.

Bore Range: 0.738" to 1.750"
(18.75 to 44.45 mm)

Torque Range: 45 to 901 lbs. ft.

Competitor Models:

Dodge 24 Series



TFS

TFS Series has two vertical keyways on the outer race to assist with positioning. Outside dimensions are the same as series 63 ball bearings. Ideal for general overrunning applications.

Bore Range: 0.472" to 3.150"
(12 to 80 mm)

Torque Range: 13 to 2,894 lbs. ft.

Competitor Models:

Formsprag ASNU
Morse NFS
Ringspann FC/FDN

Timing and General Cam Clutch Products



MIUS

MIUS Series is for mid-speed indexing applications up to 300 cycles a minute.

Bore Range: 0.500" to 6.250"
(12.7 to 160 mm)

Torque Range: 280 to 27,290 lbs. ft.

Competitor Models:

Formsprag HPI
Morse MI
Marland RMS



MZ

MZ Series is designed for overrunning applications. These units come pre-lubricated for easy installation and long service life.

Bore Range: 0.591" to 2.756"
(15 to 70 mm)

Torque Range: 137 to 2,242 lbs. ft.

Competitor Models:

Stieber SMZ

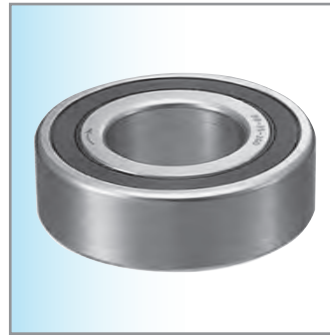

BB

BB Series has the bearing dimensions and characteristics of a 62 Series type ball bearing. This design provides easy installation and is ideal for general overrunning applications.

Bore Range: 0.590" to 1.575"
(15 to 40 mm)

Torque Range: 21 to 192 lbs. ft.

Competitor Models:

Formsprag CSK
Morse KK
Ringspann ZZ
Stieber KK



TSS

TSS Series is designed for press fit installation. Outside dimensions are the same as series 62 ball bearings.

Bore Range: 0.314" to 2.362"
(8 to 60 mm)

Torque Range: 4 to 479 lbs. ft.

Competitor Models:

Formsprag AS
Morse NSS
Ringspann FCN

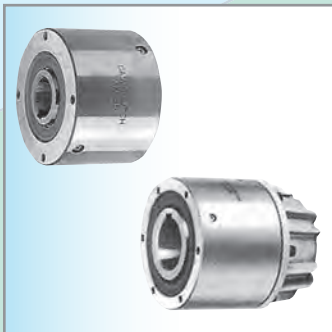

MGUS/MGUS-R

MGUS is suitable for applications which require low to high speed overrunning. MGUS-R series contains a built in oil reservoir and can be used for backstop applications.

Bore Range: 0.500" to 6.250"
(12.7 to 160 mm)

Torque Range: 280 to 27,290 lbs. ft.

Competitor Models:

Formsprag FSO
Morse MG
Ringspann FB

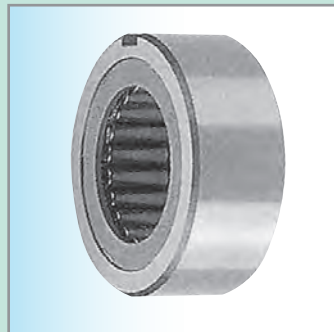

BUS200

BUS Series is specifically designed for shaft mounting applications that require high speed inner race overrunning or low to mid speed outer race overrunning.

Bore Range: 0.650" to 3.122"
(16.5 to 79.3 mm)

Torque Range: 39 to 1,025 lbs. ft.

Competitor Models:

Formsprag FS50
Morse B200
Renold SD



PBUS

PBUS Series clutch is packed with a special grease for general applications. The outer race has provisions for mounting gears, pulleys, and sprockets.

Bore Range: 0.375" to 1.750"
(10 to 45 mm)

Torque Range: 41 to 1,623 lbs. ft.

Competitor Models:

Formsprag FSR
Morse PB-A
Renold SB

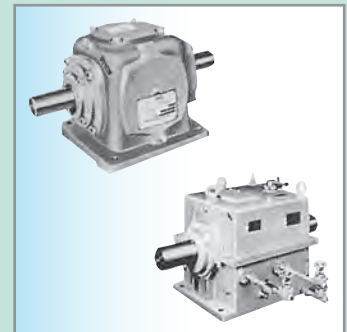

OB-ON/OF & OB-SF

OB-OB/OF Series is an enclosed unit housing cam clutch units and a common shaft. These units are used for high speed overrunning applications.

OB-SF Series is an enclosed unit housing cam clutch units that allow for continuous high speed overrunning and engagement and high torque capacities.

OB-ON/OF Torque Range: 231 to 4,337 lbs. ft.

OB-SF Torque Range: 2,318 to 59,270 lbs. ft.

Tsubaki Cam Clutch Products are designed to transmit torque in one direction of rotation and overrun (freewheel) in the opposite direction of rotation. All Tsubaki cam clutch products utilize the same principles of operation. Tsubaki offers various series of products to address the many types of applications where cam clutch products are most often used. The three most common types of applications are listed below:

Backstopping

Clutches are used to prevent reverse rotation of drive shafts which may cause damage to machinery and expensive equipment. The inner race can overrun freely in one direction of rotation. Reverse rotation is instantaneously prevented by the automatic engagement of the clutch. Typical backstop applications are in conveyor systems and gear reducers. Tsubaki has pioneered the non-rollover design.

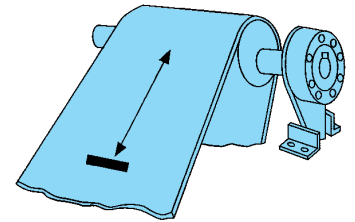
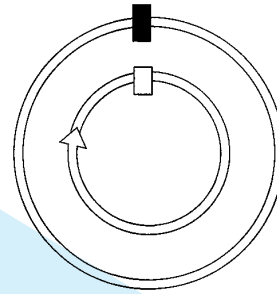

Overrunning

These clutches spin freely the majority of the time, occasionally being called upon to lock up and drive. Typical is a two-speed drive, where the machine is driven by either an electric motor or geared motor. When the gearmotor drives at low speed the clutch engages. When the faster electric motor drives, the clutch overruns, automatically switching between low speed and high speed.

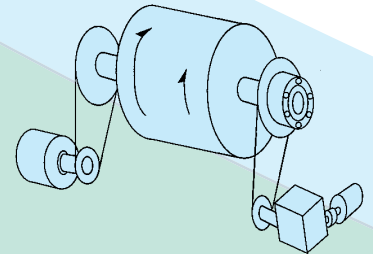
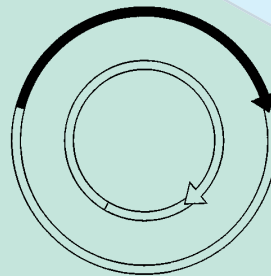

Indexing

Reciprocating motion applied to the clutch transforms into one-direction motion. A crank mechanism provides reciprocating motion to drive the cam clutch. The clutch drives in the forward stroke (index) and overruns on the return stroke, indexing the feeding roller forward.

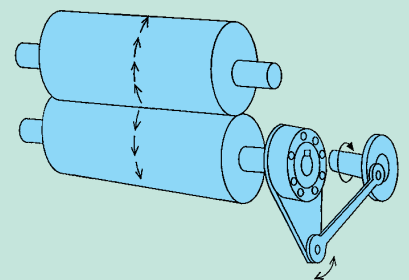
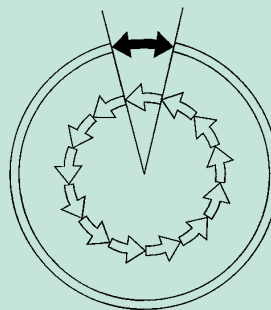



Corporate Headquarters
U.S. Tsubaki Power Transmission, LLC
301 E. Marquardt Drive
Wheeling, IL 60090
Tel: (800) 323-7790
Fax: (847) 459-9515
www.ustsubaki.com



Roller Chain Division
821 Main Street
Holyoke, MA 01040
Tel: (800) 323-7790



Conveyor and Construction
Chain Division
1010 Edgewater Drive
Sandusky, OH 44870
Tel: (800) 537-6140
Fax: (419) 626-5194



Canadian Headquarters
Sprocket Manufacturing
1630 Drew Road
Mississauga, ON L5S 1J6
Tel: (800) 263-7088



KabelSchlepp Division
7100 W. Marcia Rd
Milwaukee, WI 53223
Tel: (800) 443-4216
Fax: (414) 354-1900