



New Bulk Material Handling Drum & Sprocket Assemblies



Tsubaki now offers drum sprockets and complete shaft assemblies with the same quality and support you have come to expect from all of our Power Transmission & Motion Control products. Check inside for a summary of our new capabilities and an easy-to-use quote inquiry sheet.

Full-Face vs. A-Plate Drum Sprockets

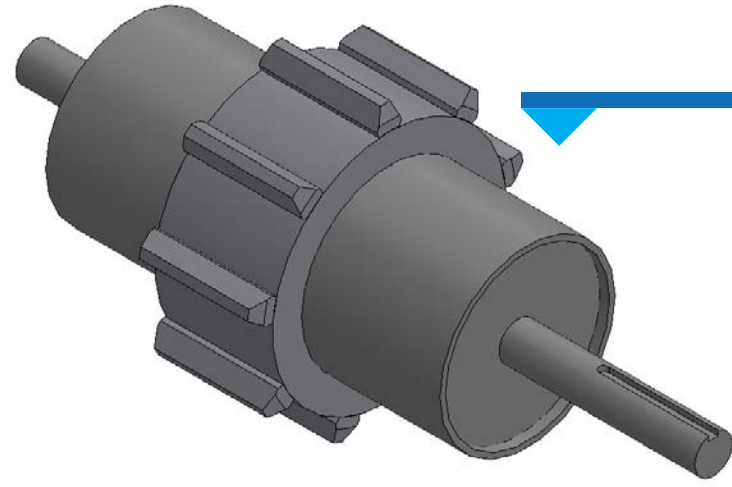

Full-Face Drum Sprocket

Increased surface area resulting in lower contact pressure between the sprocket and chain, greater wear ability make full face the standard for most applications.

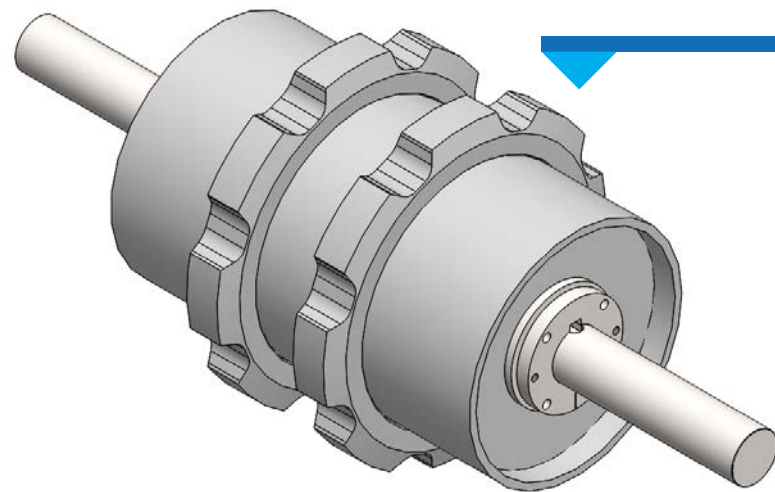

A-Plate Drum Sprockets

A-Plate style can handle greater misalignment and provide bulk material pass-through, however, less contact area may result in lower life.

Optional Style with Flange

Flanges are different than an extended shroud even though they can both service the same purpose. A flange is separate piece that is welded to a plate.

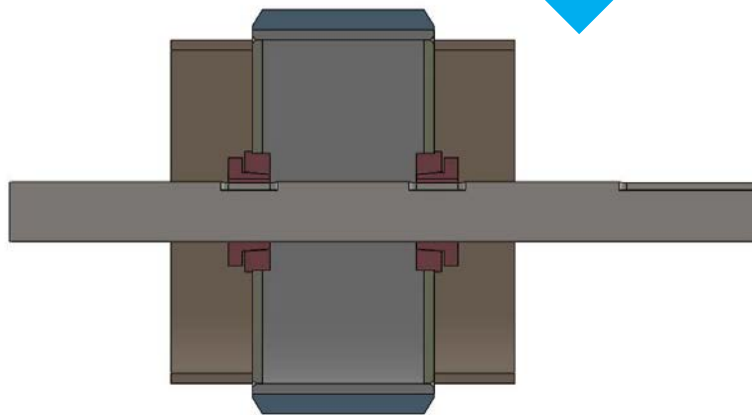

Hub Styles

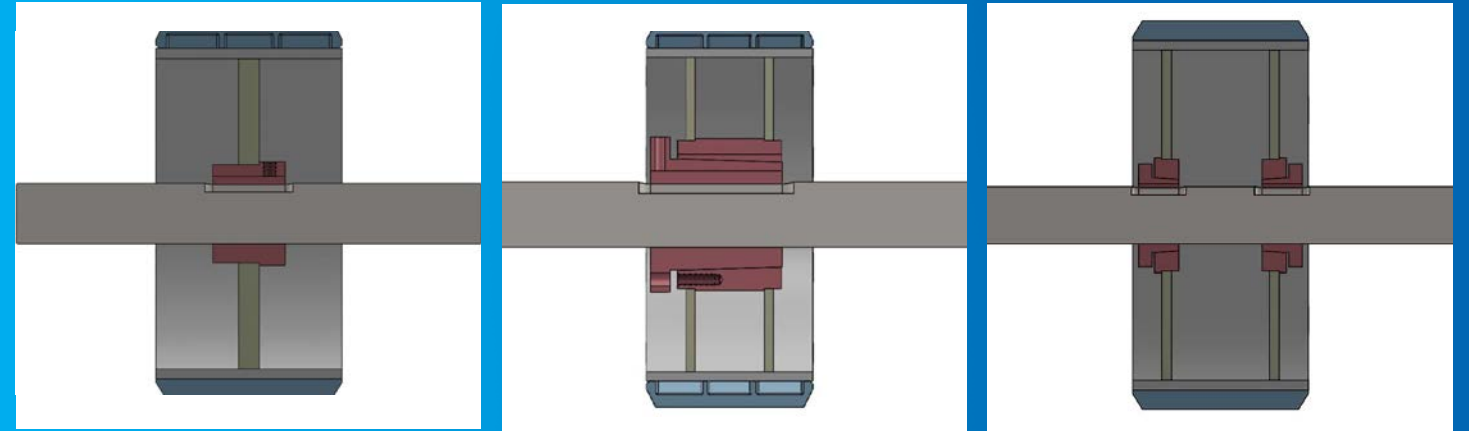

Style 1

Style 2

Style 3

Style 1 for bores up to 3-15/16". **Style 2** with double hub plates are required for bores greater than 4". Split Taper bushings are standard for single style hubs.

For ease of installation XTBS type bushings are suggested for double hub construction

TYPE	BORE	BUSHING
Single	1-7/16" to 3-15/16"	S1
	4" to 4-15/16"	U1
	5" to 5-15/16"	W1
Multi	1-7/16" to 2-15/16"	XTB30
	3" to 3-7/16"	XTB35
	3-1/2" to 3-15/16"	XTB40
	4" to 4-7/16"	XTB45

Shaft Assembly

Replacing shrunk fit components can be costly. Complete shaft assemblies reduce installation costs. Split to bolt sprockets reduce future maintenance costs.

Mounting Methods:

- Finished bore - Slip-Fit & Heat Shrunk
- Split-Taper, Taper-Lock & QD Bushing
- Split to Bolt
- Idler Sprockets (Bearing/Urethane/Bronze/Other)
- Keyless locking (e.g. Power-Lock)
- Bearing Installation

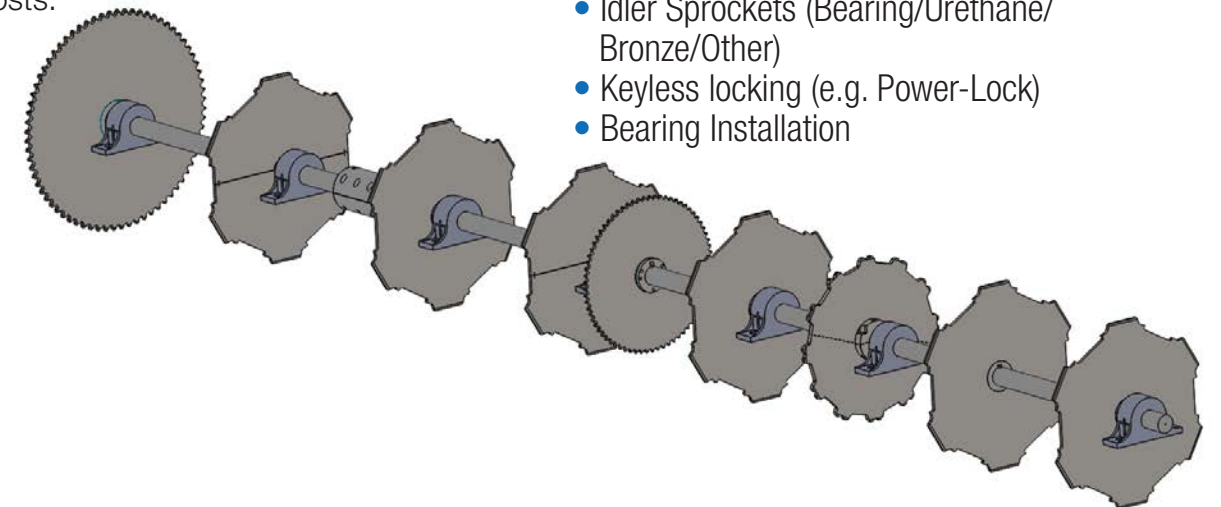

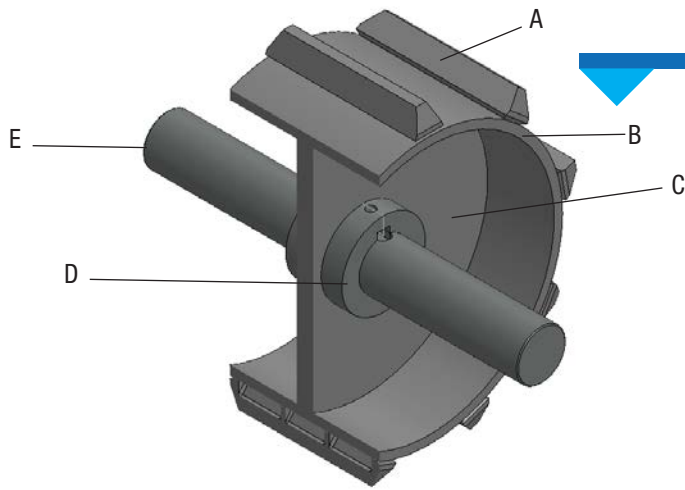

Single Drum Sprocket

Teeth engage with the chain and provide positive traction. The Can is the main structural member of a drum assembly. Optionally a drum assembly may be supplied with no teeth to create a Traction Wheel or Idler.

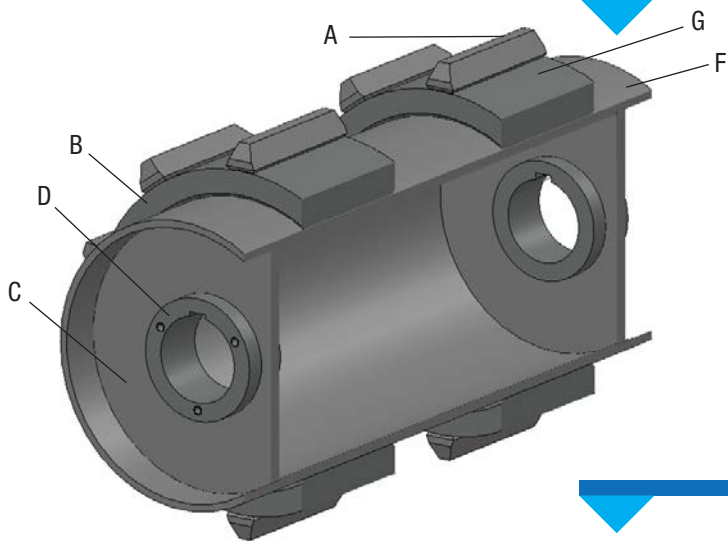

Double Drum Sprocket

To provide structural rigidity and strength, multiple-strand drums are supplied with a Shroud. Optionally multiple-strand drums may be supplied without a Shroud at customer request.

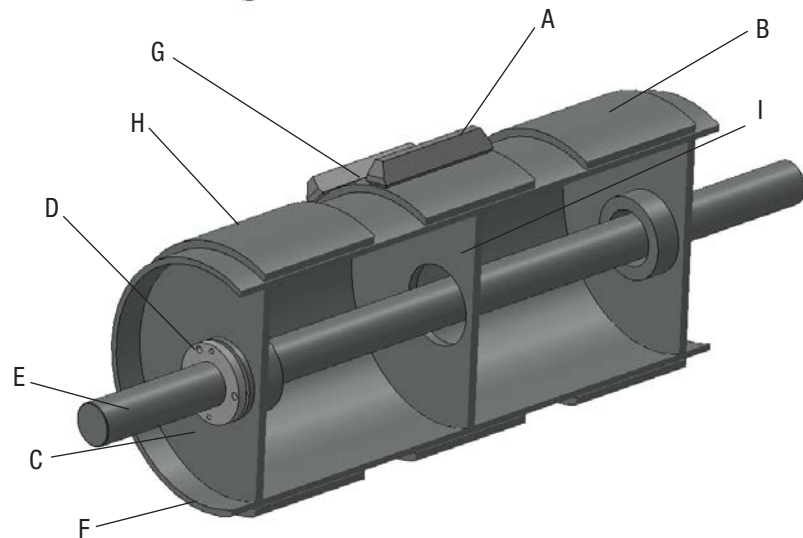

Triple Strand, Combination Sprocket & Traction Wheel

On triple drum assemblies and greater, Support Plates are installed to provide additional structural strength.

A	Teeth
B	Can
C	Hub Plate
D	Hub
E	Shaft
F	Shroud
G	Sprocket
H	Traction Wheel
I	Support Plate

Nomenclature / Part Number DR-480-1-10-A

DR	480	1	10	A
Drum Assembly	Chain Number	# of Strands	# of Teeth	A plate style, otherwise full face is standard
Quantity		Number of Strands		
Chain Size		Number of Hub Plates		
Number of Teeth		Number of Hubs		
Bore		Mounting Type		

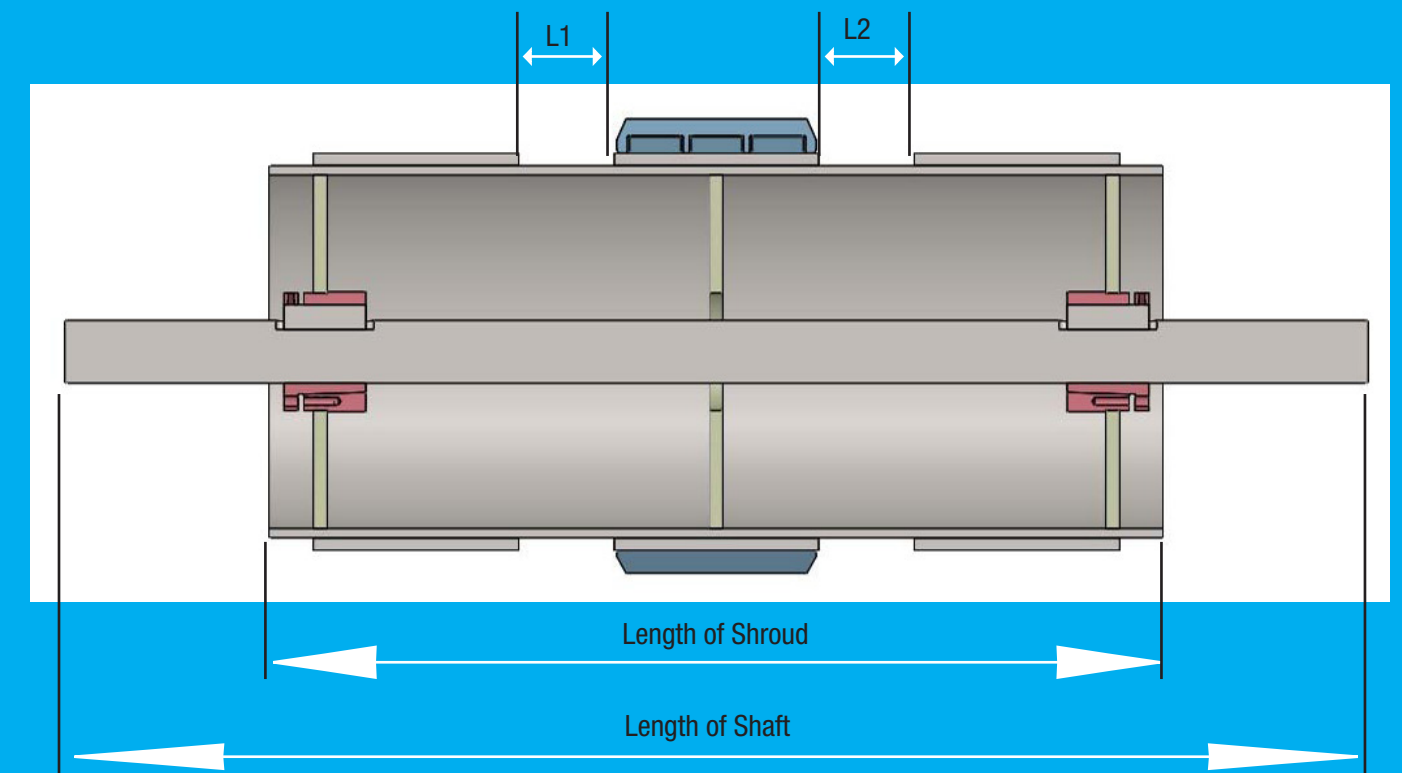

	STRAND 1	STRAND 2	STRAND 3	STRAND 4	STRAND 5
Is it a Sprocket or Traction Wheel?					
# of Effective Teeth					
Length between Strands	NA	L1=	L2=	L3=	L4=
Length of Shroud					Length of Shaft
Shaft Keyway Width			# of Keyways		
Flange Diameter					Flange Length
Bearings	YES / NO				
Brand Preference					

Send inquiry to: ecdorders@ustsubaki.com



Can be supplied in either split or non-split designs

Tsubaki can provide a variety of pillow block bearings on its drum sprockets and shaft assemblies. Whatever the application is, you can count on Tsubaki for high-quality drum sprocket and shaft assemblies with pillow block bearings.

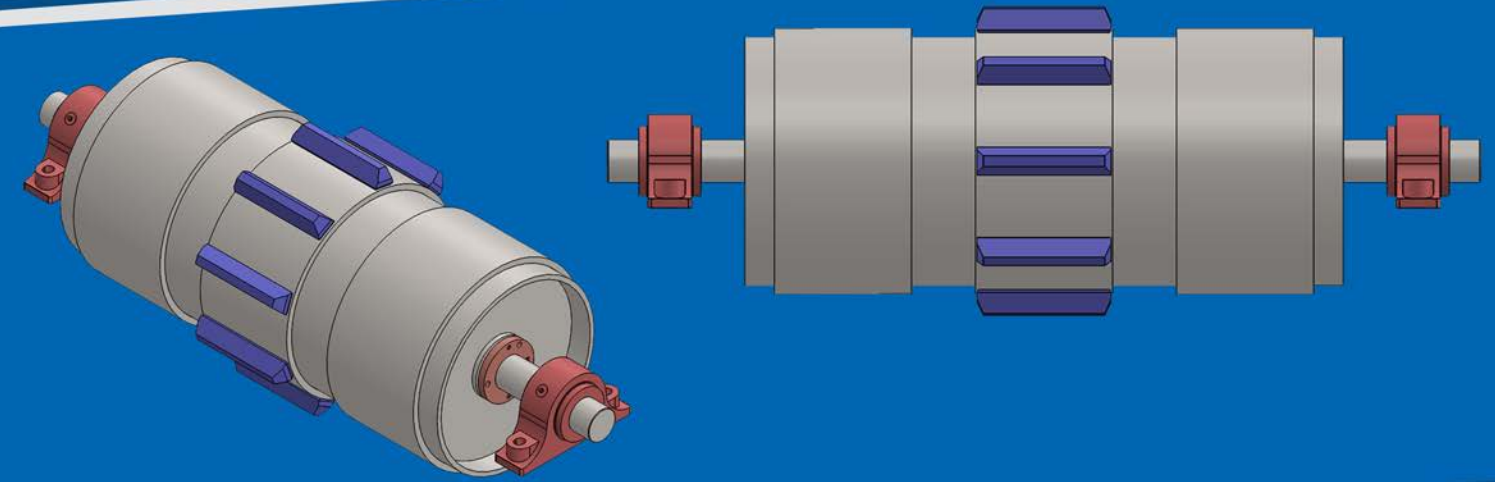

DESIGNED FOR QUICK, EASY AND SAFE MOUNTING

- Tsubaki can supply your drum sprocket or shaft assembly pre-assembled with bearings to decrease installation time for your application.
- One-piece options have sturdy ductile iron or steel housings to withstand high shock and impact from falling debris.
- Assemblies come sealed and pre-greased at the factory.
- Split options are available for easy installation.

	BEARING SELECTION
Bore Size	
2 Bolt or 4 Bolt	
Number of Fixed	
Number of Floating	
Brand / Part #	

BEARING CONSTRUCTION

- Available in 2 and 4 bolt designs
- Available fixed and floating to accommodate misalignment
- Lubricated with premium industrial grease

- Bearings are available with super-finished rollers for less noise, and raceway designs that accommodate higher misalignment.

Tsubaki now offers drum sprocket and shaft assemblies with brand name bearings you can trust.

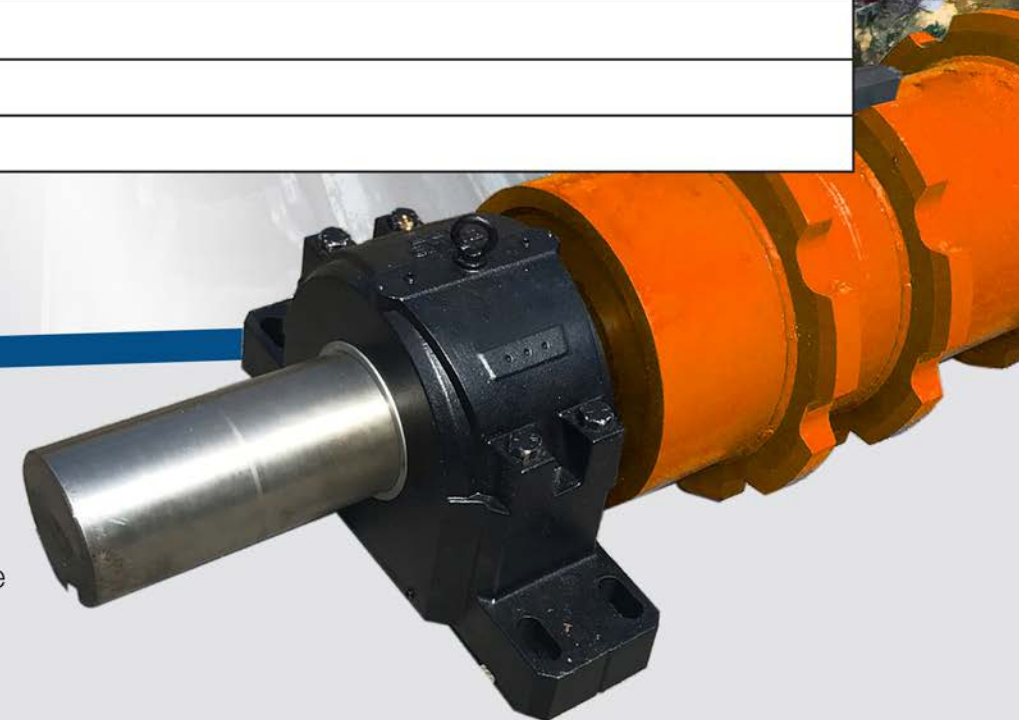

MORE INNOVATIVE SOLUTIONS FROM TSUBAKI



EXCELLENCE THROUGH INNOVATION SINCE 1917

For over 100 years, Tsubaki has developed and manufactured the highest-quality products for power transmission and motion control. With a vast network of global production facilities, R&D resources and sales offices, Tsubaki remains committed to providing innovative solutions to customers' problems for the next 100 years.



Corporate Headquarters
U.S. Tsubaki Power Transmission, LLC
301 E. Marquardt Drive
Wheeling, IL 60090
Tel: (800) 323-7790
www.ustsubaki.com



Roller Chain Division
821 Main Street
Holyoke, MA 01040
Tel: (800) 323-7790



**Conveyor and Construction
Chain Division**
1010 Edgewater Drive
Sandusky, OH 44870
Tel: (800) 537-6140



Sprocket Manufacturing
1630 Drew Road
Mississauga, Ontario
Tel: (800) 323-7790



Cable & Hose Carrier Division
7100 W. Marcia Road
Milwaukee, WI 53223
Tel: (800) 443-4216

Note: In accordance with the policy of U.S. Tsubaki Power Transmission, LLC to consistently improve its products, the specifications in this brochure are subject to change without notice. The logos, brand names or product names in this brochure are trademarks or registered trademarks of Tsubakimoto Chain Co. and its subsidiaries in Japan, the U.S. and other countries.